

Thomas Henry **PAL** Filter (Eurorack DIY)



Introduction (With the words of Thomas Henry)

“What, another filter? Yes, and there's a good reason for it. When it came time to design a filter for my synthesizer, I was struck by how many exotic designs already existed - phase filters, polygonal filters, multimode filters, and filters which did everything but clean the sink. On the other end of the scale there were noisy filters, trashy filters, worthless filters, and filters which hardly filtered at all! What I wanted was a good quality, middle of the road filter - and this design is the result. [...]

The PAL came about because depending on how you adjust the controls, you can have a Phase shifter, All pass filter, or Low pass filter. In addition to the usual voltage controlled options, this unit also features voltage controlled resonance.”

(Thomas Henry 1982)

Features

- CEM-3320 (AS3320) based 4-pole 24dB LoPass filter,
- CV input with attenuator,
- CV input for 1V/Octave,
- CV input with attenuator for resonance,
- Coarse and Fine tuning pots,
- Mode switch (lowpass/allpass)

Specifications

- The frontpanel measures: 10HP (Eurorack)
- Mounting depth behind frontpanel incl. power plug: 40mm
- Power consumption: +36mA/-40mA

BTW this is not meant as a beginners project. I do not provide step-by-step building instructions. I just assume that you already build quite a few projects and know how to read the BOM and schematics.

What, another filter? Yes, and there's a good reason for it. When it came time to design a filter for my synthesizer, I was struck by how many exotic designs already existed - phase filters, polygonal filters, multimode filters, and filters which did everything but clean the sink. On the other end of the scale there were noisy filters, trashy filters, worthless filters, and filters which hardly filtered at all! What I wanted was a good quality, middle of the road filter - and this design is the result.

Now, don't get me wrong; I like fancy filters too. But I don't want to play synthesizer in the poor house. The filter I came up with is very clean, but won't cost you an arm and a leg. The good quality at a low price comes from using the CEM-3320 integrated circuit made by Curtis Electromusic. I think you'll find the unit is very versatile and yet easy to understand.

How it works: Theme PAL came about because depending on how you adjust the controls, you can have a Phase shifter, All pass filter, or Low pass filter. In addition to the usual voltage controlled options, this unit also features voltage controlled resonance.

Referring to the schematic, the heart of the filter is the CEM-3320, which does all the hard work for us. In fact, all we really have to do is supply it with the correct voltages. For example, look at the resonance controls going to pin 9...two 100k resistors is all it takes! R42 is an initial resonance control, and J5 is the voltage controlled input. R28 and R29 convert the input voltages to currents which are then Summed into pin 9 of the CEM-3320. (For the purists in the crowd, pin 9 is not quite at virtual ground, but is close enough to pull the summed current trick. Since resonance doesn't

require the precision that frequency does, a two resistor summer works quite well.)

J3 is the audio input. A1 is set up in such a way that the audio signal is shifted up to about half of the positive supply voltage, which is done to interface more easily with the CMOS circuits we'll encounter later. Note that the output of A1 feeds both the filter proper and also R40, the output blend control. And as long as we're talking about the blend control, let's note that the other side of R40 is at a half supply bias as well. This guarantees that there won't be any weird DC level shifts as you pan the pot. At the same time, notice that this lets us preserve DC coupling from the output of the filter.

The wiper of the blend control feeds A2, which is set up to undo the biasing mentioned above. R43 shifts the DC back down to 0V and R35, the output offset trim, lets us trim this precisely.

Many of you are probably wondering why I went to all this trouble, first shifting the bias up and then back down again. Well, besides the CMOS considerations that we'll be touching on shortly, the net result of all this is that we get to keep the filter DC coupled from input to output. In general, I like all of my synthesizer circuits to be DC coupled if at all possible, since this means I never have to differentiate between audio or control signals. Granted you'll probably use the filter for audio processing most of the time, but there may also be times when you want to put a jagged control signal into the filter and smooth it down by setting a relatively low corner frequency.

A4 and its associated components provides voltage control of the corner frequency. R37 and R38 provide coarse and fine tuning respectively. J2 is an envelope input with attenuator, and provides a gain of about three. The gain is there so that you

can sweep the filter over its entire range with a standard 5V output envelope generator. J1 is the one Volt per octave input, and would typically be driven by the keyboard.

R13 is the Volts per octave trimmer. R30 and R5 drop the voltage to an appropriate level before applying it to pin 12 of the CEM-3320. Note that the chip has been temperature compensated for all second order effects, however a first order, or linear, temperature dependence still exists. If you feel that this is going to be a problem, you may substitute a 1.8k thermistor for R5, and this will null out all temperature dependence. It has been my experience, however, that filters generally don't need the precision of something like a VCO.

So far, we have examined the standard features which you might expect to see with any filter; now let's look at the single most unusual feature of this circuit. AS1-AS8 are analog switches (each is 1/4 of a CD4066), and have been set up pair wise to form single pole, double throw switches. Essentially each one of these SPDT affairs will switch the tuning capacitors either between ground or the input resistors of the gain cells. With the capacitors hooked

to ground, you have a low pass filter; when they're swung to the gain cell input resistors, you get an all pass filter. I used electronic switching for several reasons: first, who wants to solder all those wires! Besides, a couple of 4066s are less expensive than a ganged, rotary switch (one ordinary SPST switch, S1, does the job now).

A3 is set up as an inverter so that when one side of the 4066 switch is enabled, the other side is disabled. Since I used a quad op amp for this project, and had one op amp I left over anyway, it was convenient to do things in this manner.

Calibrating the PAL. Follow this procedure exactly:

1. Turn R39, R41, and R42 down completely. Turn R37 and R38 to the center of their rotations. Monitor the output at J4 with an oscilloscope or multimeter (the higher the impedance, the better).
2. Turn the blend control, R40, for full filter output. Adjust R34 until the output reads OV.
3. Turn the blend control, R40, for full straight signal at the output. Adjust R35 until the output reads OV.
4. Repeat steps 2 and 3 until the output reads OV no matter position R40 is in.
5. Now turn R39 up full and apply a 1 Hz signal to J2 (use the LFO from your synthesizer for this if you want). The signal should be about 10V peak-to-peak in amplitude. Now while monitoring the output, adjust R4 for minimum control voltage feedthrough.
6. Finally adjust R13, the Volts per octave trim. This is best done with your keyboard hooked up to J1. Set the filter into oscillation by turning resonance control R42 full up. Now tune the filter like any VCO by comparing accuracy at different octaves.

Applications:

First, set S1 to the low pass mode and turn blend control R40 to full strength filter output. The filter is now acting like a standard low pass filter.

Next, put S1 in the all pass mode and keep the blend control on full strength filter output. Sweep the coarse frequency control, R37, and notice the pitch shift characteristic of all pass filters.

Now keep S1 in the all pass mode, but blend in some straight signal. Sweep the coarse control and notice the typical "swooshing" sound of a phase shifter.

As I mentioned in the opening paragraph, there are lots of filters around and some of them are hard to use. I think you'll find this one is exceptionally easy to use, yet has enough novel features to make its inclusion in any synthesizer system worthwhile. And by the way, in my original prototype I had some front panel space left over, so I included the ADSR circuit I presented here several months ago. Let me tell you, an ADSR and VCF combination makes for a great pair! Happy building!

Layout/Design

General mounting instructions

This project uses two PCBs, one board with the actual circuitry and an additional adapter PCB carrying the front panel components. The adapter PCB is used to mount the PCBs to the front panel.

The PCBs are connected using two 1x10 headers/receptables with 2,54mm pitch (.1in). Look out for something like this:

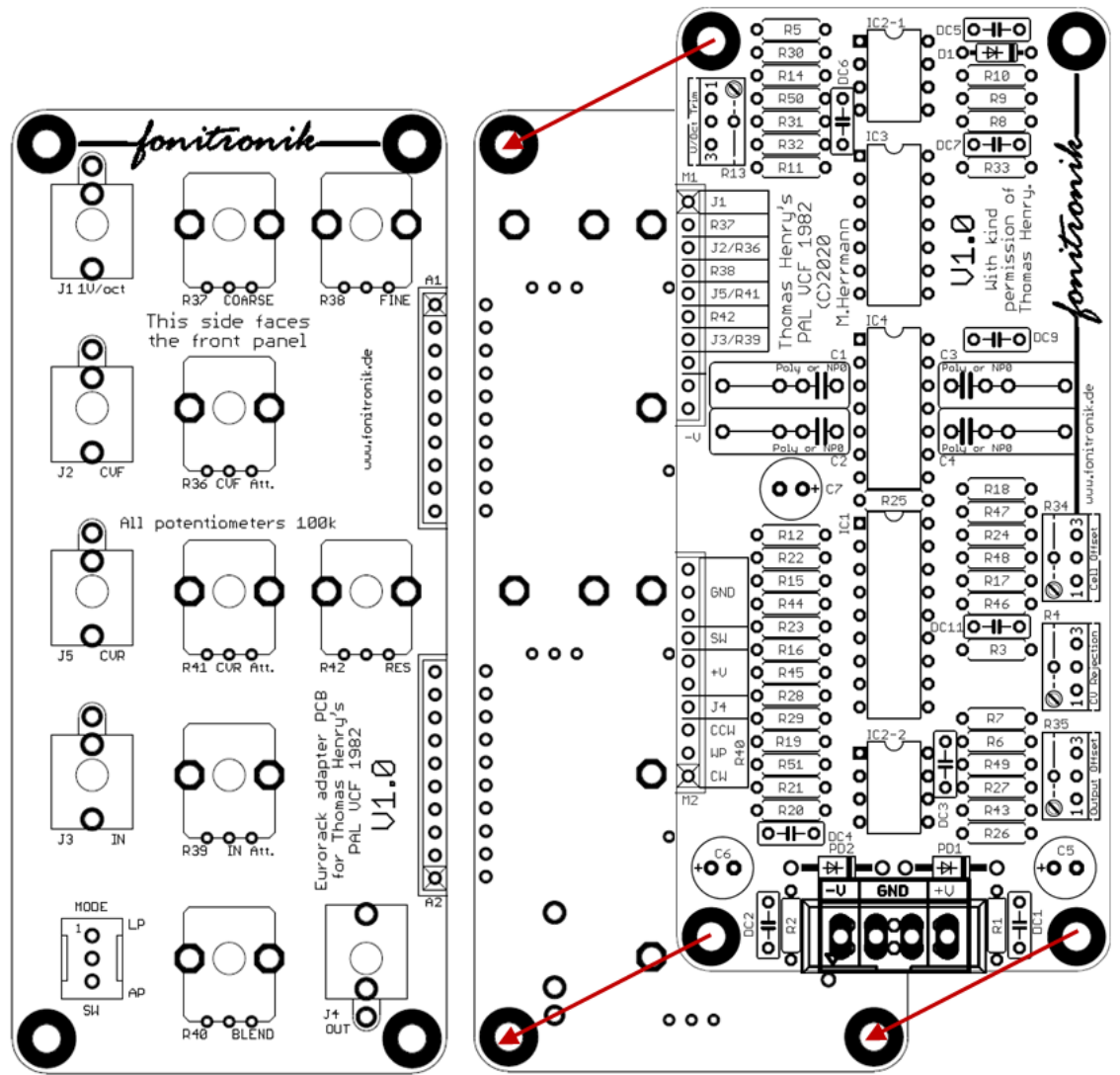

Overlay for Reference

For manual wiring refer to schematic (last page of this document)

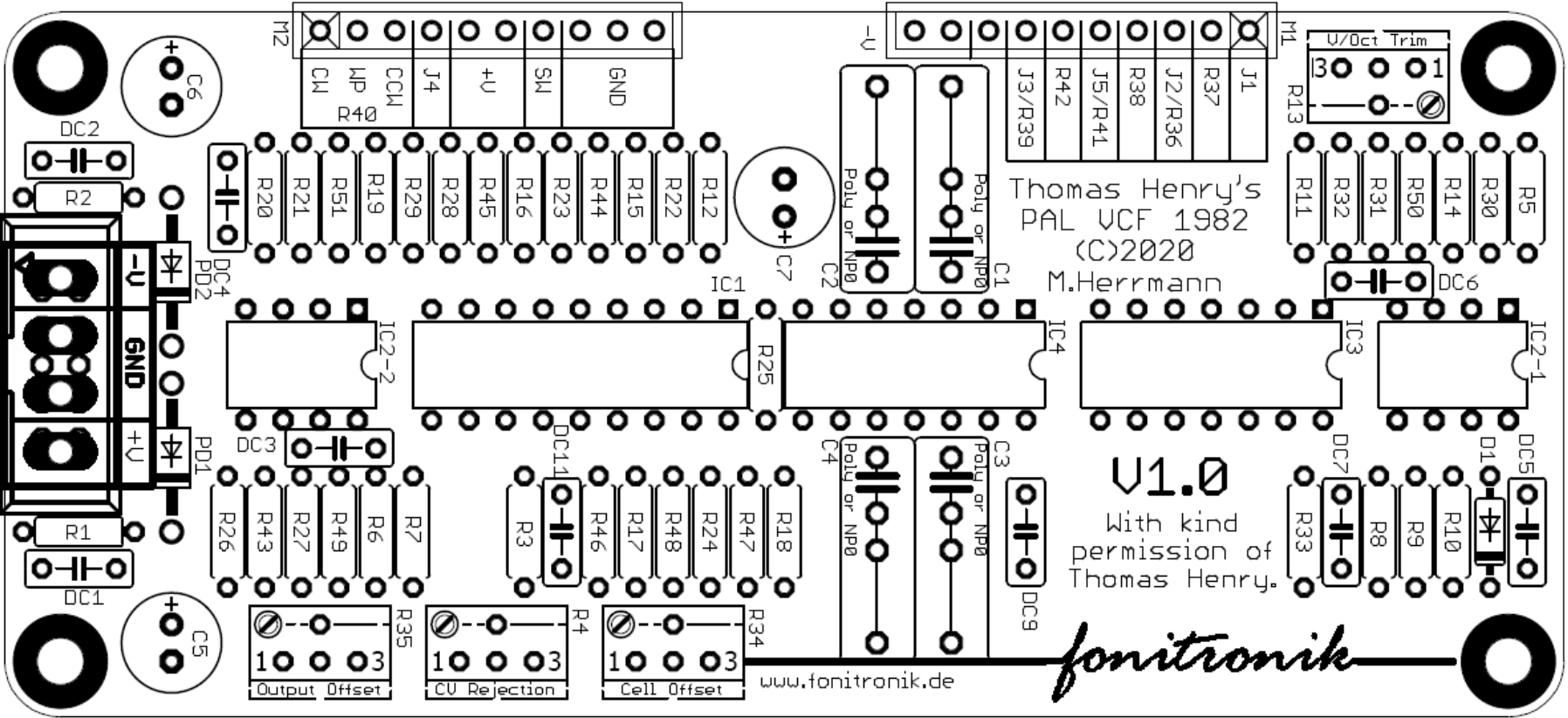

BOM

Qty	Value	Parts
Resistors		
2	10R or ferrite	R1, R2
1	1k	R3
1	2k TEMPCO	R5
2	2k2	R6, R7
2	10k	R8, R9
1	33k	R10
1	39k	R11
1	50k	R13
2	82k	R12, R14
4	91k	R15, R16, R17, R18
15	100k	R19 , R20, R21, R22, R23, R24, R25, R26 , R27 , R28, R29, R31, R32, R33, R43
1	110k	R30
5	220k	R44, R45, R46, R47, R51
2	1M	R48, R49
1	3M3	R50
1	1k Trimmer	R4
2	100k Trimmer	R34, R35
Capacitors		
4	330pF (poly)	C1, C2, C3, C4
9	100n	DC1, DC2, DC3, DC4, DC5, DC6, DC7, DC9, DC11
1	1uF/16	C7
2	33uF/35	C5, C6

Qty	Value	Parts
Semi's		
1	1N4148	D1
2	1N4004	PD1, PD2
1	CEM3320	IC1 (or AS3320)
2	OPA2134	IC2-1, IC2-2 (or other Dual OpAmp)
2	CD4066	IC3, IC4
Misc (Adapter PCB)		
1	SPDT on-on (miniature)	SW1
7	100k (9mm Potentiometer)	R36 - R42
5	Socket (PJ-301B)	J1 - J5
2x	10pol SIL header (female)	
2x	10pol SIL header (male)	

UNTESTED:

When using **DG412** (full swing) for IC3, IC4
no signal shift is needed:

- omit R35, R43, R49, R51
- R19, R26, R27 = 0R (jumper)

For private use only. Do not copy and/or distribute by any means.

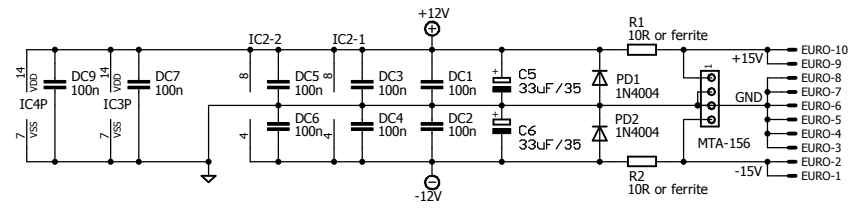
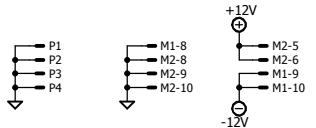
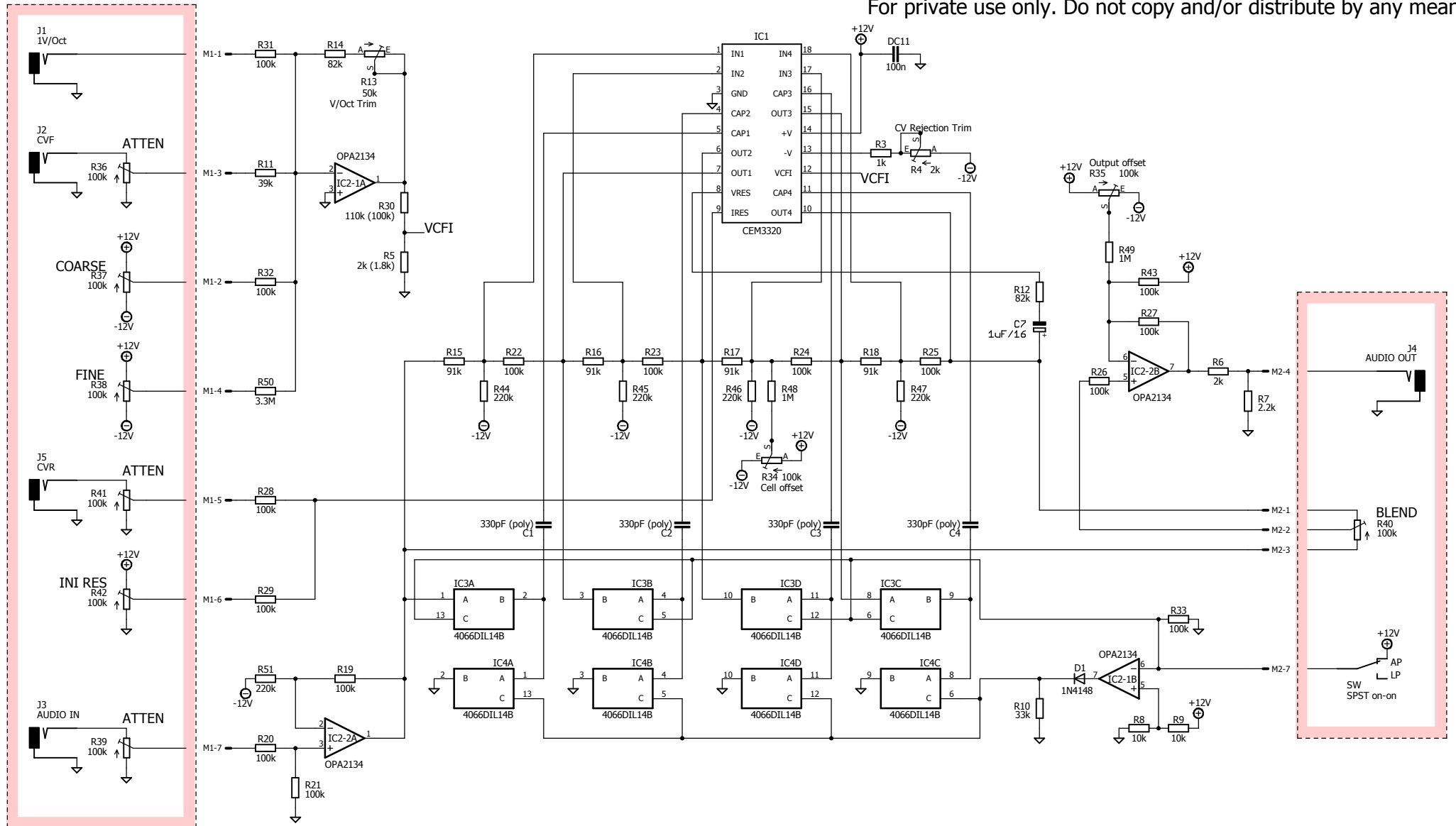

THOMAS HENRY - PAL Filter	
published in Polyphony 3/1982 Redrawn schematic by Matthias Herrmann 2020	
TITLE: PAL-Filter-CB-10HP	
Document Number:	REV: 1.0
Date: nicht gespeichert!	Sheet: 1/1